

Features

- ➔ DC - 500MHz
- ➔ 22 dB Gain at 70MHz
- ➔ +20.5 dBm P1dB
- ➔ +42 dBm Output IP3
- ➔ Single Voltage Supply
- ➔ Lead-free / Green / RoHS-compliant SOT-89 Package

Applications

- ➔ IF Amplifier
- ➔ VHF/UHF Transmission
- ➔ Mobile Infrastructure
- ➔ RFID/ Fixed Wireless

Functional Diagram

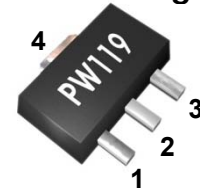

Function	Pin No.
RF IN	1
RF OUT / Bias	3
Ground	2,4

Description

The PW119 is a high performance InGaP HBT MMIC Amplifier and consists of Darlington pair amplifiers with temperature compensation. The amplifier features high linear performance, high reliability as an IF amplifier and provides stable current variation over temperature. The PW119 operates from a single voltage supply and requires only two DC-blocking capacitors, a bias resistor and an inductor for operation. The device is a general purpose IF amplifier that offers high dynamic range in a low cost surface-mountable plastic SOT-89 packages.

Specifications

Symbol	Parameters	Units	Freq.	Min.	Typ.	Max.
S21	Gain	dB	70 MHz 140 MHz 250 MHz 500 MHz		22.1 22.0 21.8 21.5	
S11	Input Return Loss	dB	70 MHz 140 MHz 250 MHz 500 MHz		-20 -25 -20 -15	
S22	Output Return Loss	dB	70 MHz 140 MHz 250 MHz 500 MHz		-20 -20 -15 -11	
P1dB	Output Power @1dB compression	dBm	70 MHz 140 MHz 250 MHz 500 MHz		20.5 20.5 20.4 20.1	
OIP3	Output Third Order intercept	dBm	70 MHz 140 MHz 250 MHz 500 MHz		42.0 40.5 39.0 36.0	
NF	Noise Figure	dB	70 MHz 140 MHz 250 MHz 500 MHz		2.9 2.9 2.9 2.9	
V / I	Device voltage / current	V/mA			4.66/115	
Rth	Thermal Resistance	°C/W			73	
Tj	Junction Temperature	°C			125	

Test Conditions : T=25°C, Supply Voltage=+5V, Rbias=2.4ohm, 50ohm System, OIP3 measured with two tones at an output power of +9dBm/tone separated by 1MHz.

Typical RF Performance for IF Amp Application Circuit

Supply Bias Voltage = 5V, R(bias)= 2.4ohm, Current= 115mA

Frequency	MHz	50	70	140	250	500
S21	dB	22.3	22.3	22.2	22.0	21.6
S11	dB	-20	-23	-30	-25	-20
S22	dB	-20	-25	-25	-18	-12
P1dB	dBm	20.6	20.6	20.6	20.5	20.3
OIP3(@9dBm)	dBm	42.3	42.1	41.0	39.5	36.5
Noise Figure	dB	2.9	2.9	2.9	2.9	2.9

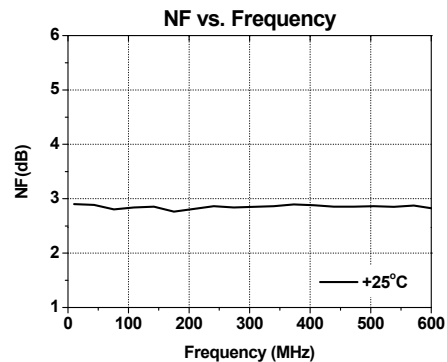
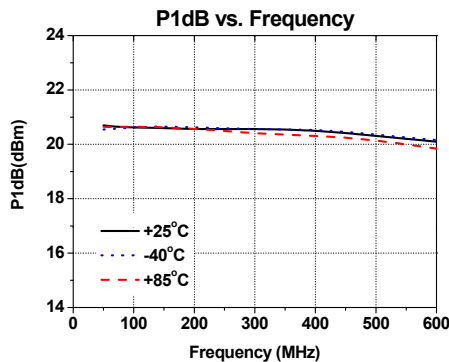
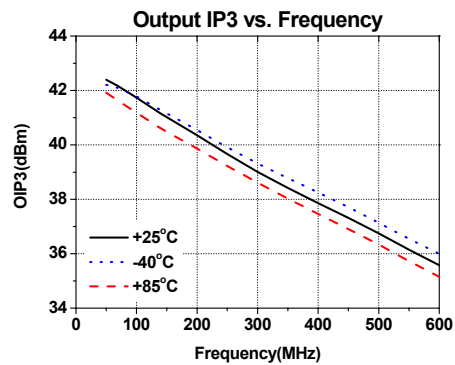
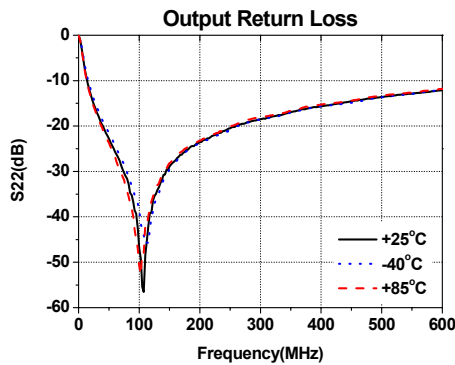
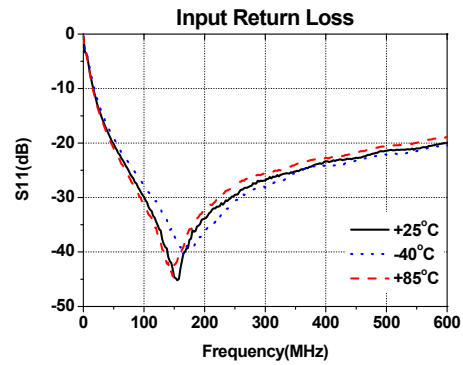
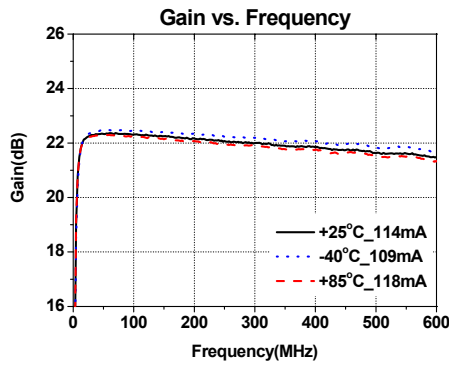

IF Amp Application Circuit

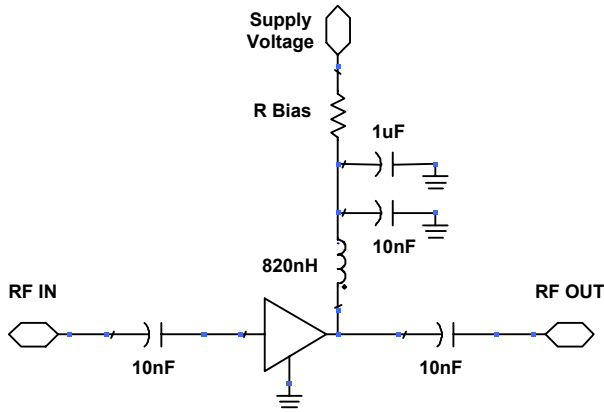

Recommended Bias Values

Supply Voltage	R bias Value	Size
5 V	2.4 Ω	0805
5.3 V	5.0 Ω	0805
6 V	11.0 Ω	0805
7 V	19.7 Ω	1210
8 V	28.3 Ω	1210
9 V	36.9 Ω	2010
10 V	45.5 Ω	2010
12 V	62.8 Ω	2512

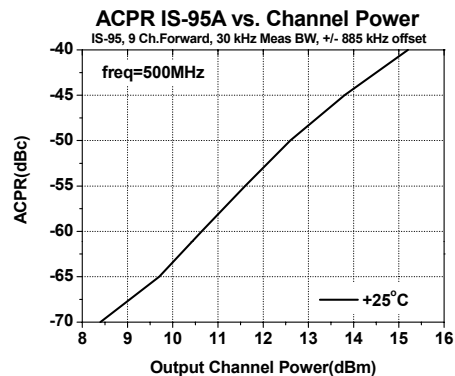
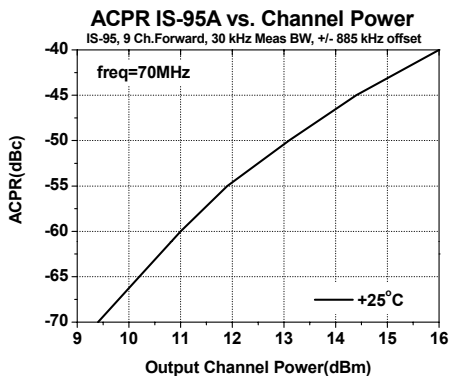
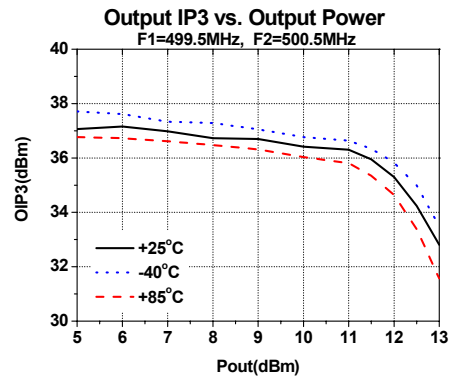
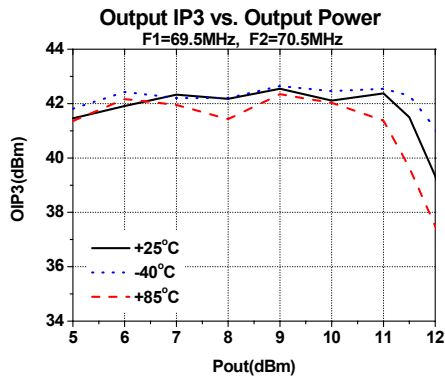
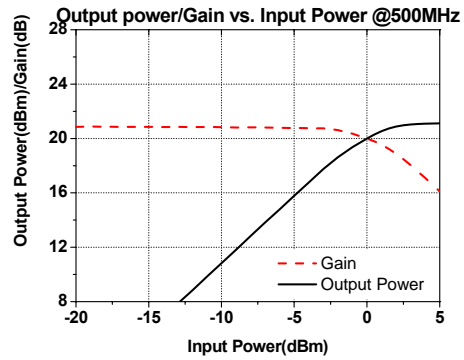
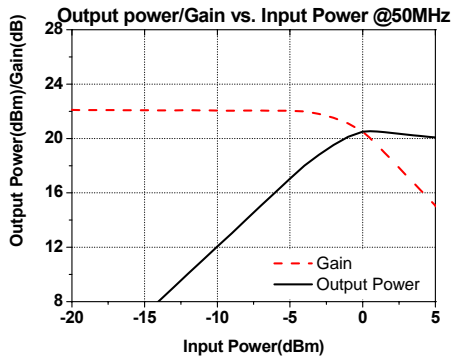

Absolute Maximum Ratings

Parameter	Rating	Unit
Supply Voltage	+7	V
Supply Current	300	mA
RF Power Input	10	dBm
Storage Temperature	-55 to +125	°C
Ambient Operating Temperature	-40 to +85	°C
Junction Temperature	215	°C

Operation of this device above any of these parameters may cause permanent damage.

Lead-free /RoHS Compliant / Green SOT-89 Package Outline

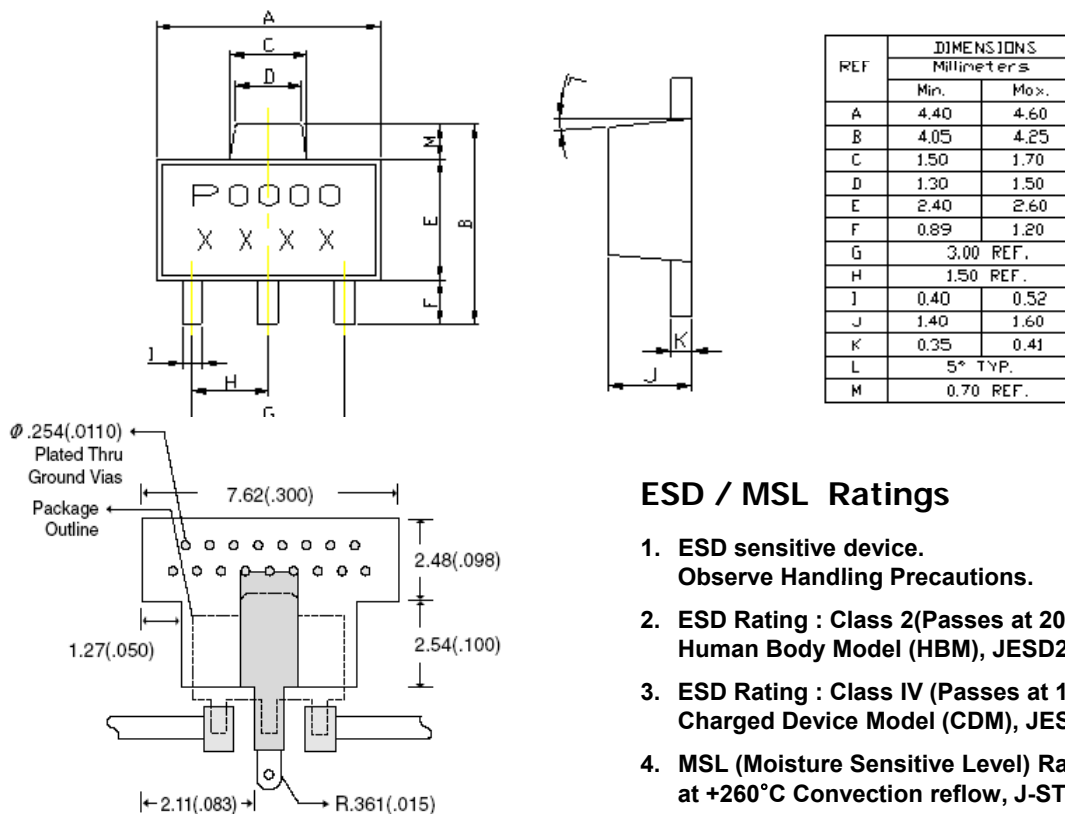

ESD / MSL Ratings

1. ESD sensitive device.
Observe Handling Precautions.
2. ESD Rating : Class 2(Passes at 2000V min.)
Human Body Model (HBM), JESD22-A114
3. ESD Rating : Class IV (Passes at 1000V min.)
Charged Device Model (CDM), JESD22-C101
4. MSL (Moisture Sensitive Level) Rating : Level 3
at +260°C Convection reflow, J-STD-020

Evaluation Board Layout (4x4)

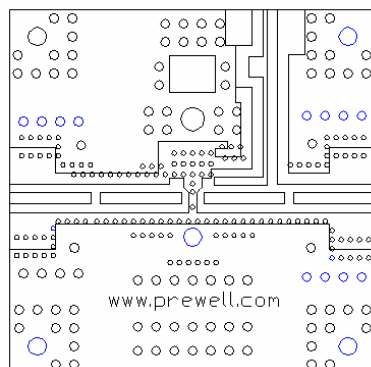

Mounting Instructions

1. Use a large ground pad area with many plated through-holes as shown.
2. We recommend 1 oz copper minimum.
3. Measurement for our data sheet was made on 0.8mm thick FR-4 Board.
4. Add as much copper as possible to inner and outer layers near the part to ensure optimal thermal performance.
5. RF trace width depends on the board material and construction.
6. Add mounting screws near the part to fasten the board to a heatsink.

<http://www.prewell.com>